

## DSP7052

### 5" 20W Ceiling Speaker



#### Description

The DSP7052 is a ceiling speaker. It provides a perfect sound reinforcement solution with its simplicity, fashion, and excellent sound quality. It is built with two 1-inch tweeter units and one 5-inch woofer unit, making it perfect for homes, offices, and commercial spaces. Its sleek design seamlessly blends into any decor, while its easy installation and durable construction ensure a hassle-free and long-lasting audio experience.

#### Features

- Compact ceiling-mounted design with a minimalist and stylish appearance
- Delivers clear and balanced sound for background music applications
- Supports 70V/100V line voltage operation for flexible installation
- Wide 130° coverage angle ensures even sound distribution
- High sensitivity for improved audio efficiency and performance
- Wide frequency response from 50Hz to 20 kHz for full-range sound reproduction
- Easy and secure installation suitable for various ceiling types
- Durable construction with long service life
- Neutral white finish blends seamlessly into most interior environments

Model	DSP7052
Rated Power	20W
Constant Voltage 70V	2.5W/5W/10W
Constant Voltage 100V	5W/10W/20W
Sensitivity	90dB
Frequency Response(-10dB)	50-20KHz
Coverage Angle (1KHz/-6dB)	130°
Dimension(W*D)	Φ203×85mm
Weight	1.4 kg
Color	White

## Product Information

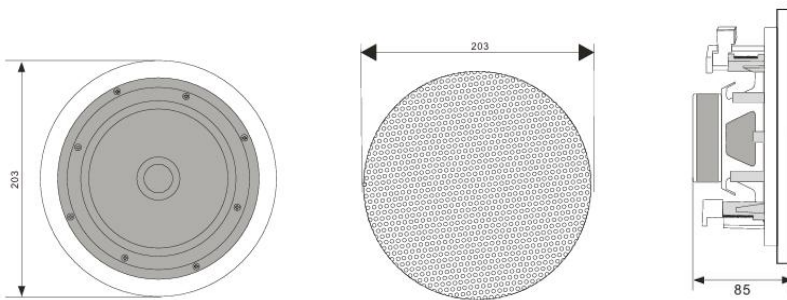

## Product Installation

1. Step one: Open a  $\phi 180\text{mm}$  hole in the ceiling.

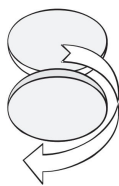

2. Step two: Remove the mesh mask.

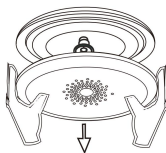

3. Step three: Press the open hole in advance, install the product to the ceiling, and lock the screws.

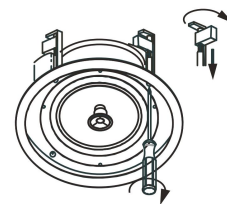

4. Step four: After the product is fixed, reload the mesh mask.

